

FH1350

WOODSMAN PRO™

CONTINUOUS ROTATION FELLING HEAD

WOODSMAN PRO™ FH1350

Designed for high production felling, shovel logging and grapple operations on any terrain, this felling head has a proven track record of strength and reliability with minimal maintenance costs.

Our continuous 360° rotation felling head weighs 2.2 tonnes and can be attached to any 25-35 tonne base machine.

The powerful 60 cc saw motor will cut through the largest stems and together with dual clamp arm cylinders, provide greater holding power, critical to tree felling.

A control valve is mounted in the head and installation costs are kept to a minimum – only three hydraulic and one electrical connection required.

DESIGNED AND
MANUFACTURED BY



WOODSMAN PRO™
FH1350 DESIGNED AND MANUFACTURED BY ENSIGN

WOODSMANPRO.CO.NZ



FEATURES

- Continuous 360° rotation for manoeuvrability.
- 3 hydraulic connections to the base machine.
- Individual clamp arm cylinders for greater hold power.
- Powerful saw motor (60 cc).

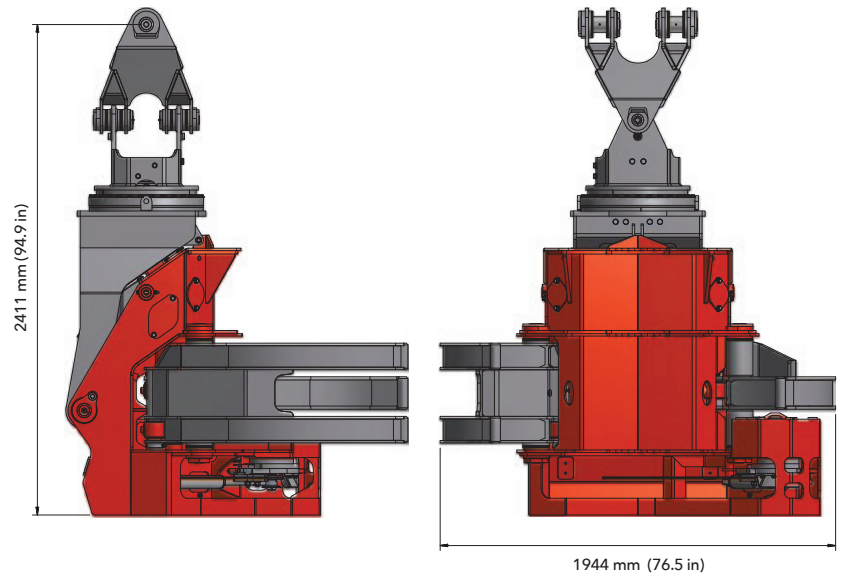
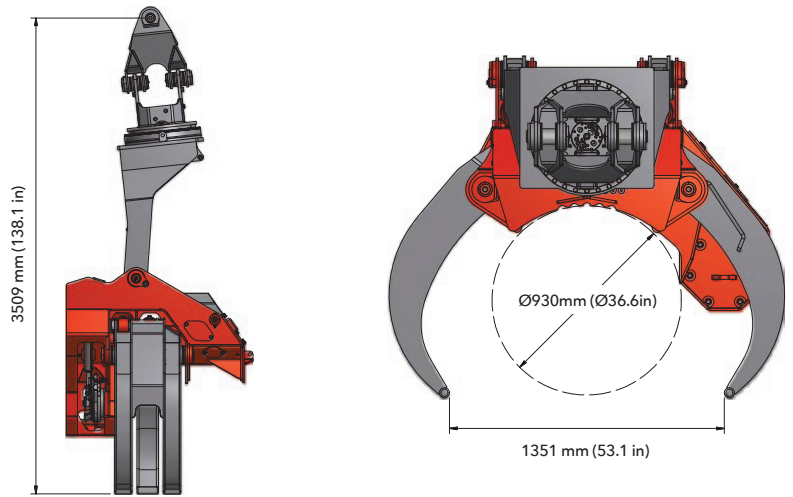

DIMENSIONS

Weight: 2175 kg (4795 lb)

Max opening: 1351 mm (53.1 in)

SAW

Saw pitch: 0.75 in

Max saw cut: Ø930 mm (Ø36.6 in)

Bar length: 38, 40, 43 in

Bar oil tank cap: 24 L

WOODSMANPRO.CO.NZ

P. +64 7 348 1286
E: INFO@ENSIGN.CO.NZ

ENGINEERING SERVICES ROTORUA LTD
73 Biak St, Waterford Park, Rotorua, New Zealand.